

TF150BB09-100 B

HIGH POWER BeO TERMINATION

SPECIFICATIONS

FILE: TERMOUT

POWER MAX
(WATTS):

150 CW

RESISTANCE

50 OHMS (±5%)

CAUTION

THIS SUBSTRATE USES BERYLLIUM OXIDE
USE CARE WHEN HANDLING.
DO NOT SCRATCH OR ABRASIVE
TRIM IN OPEN AREA.

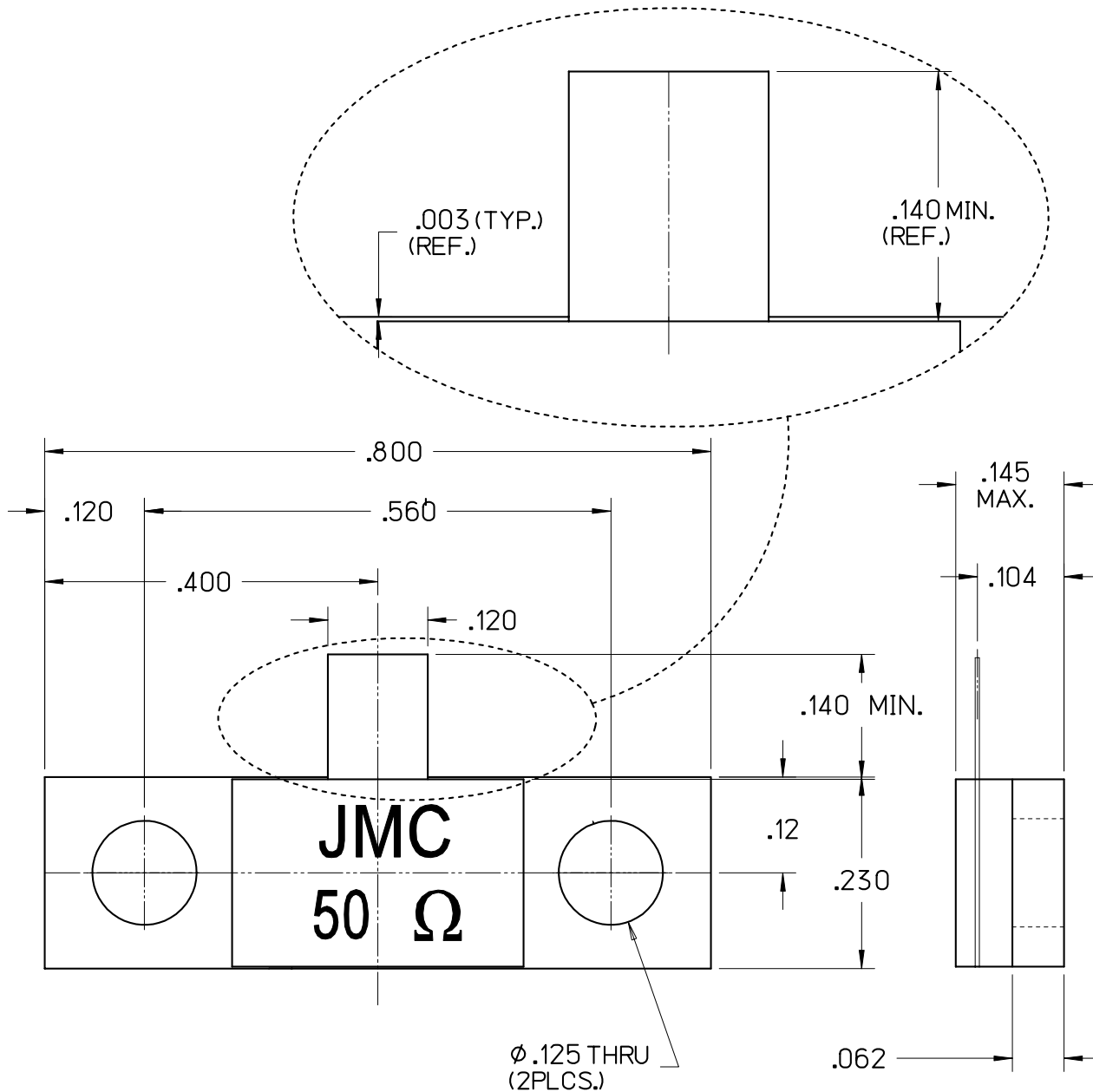

B	10/30/07	MLD	MAI	MAI	000607
A	03/01/07	MLD	-	-	000512
LEVEL	DATE	DRN.	CHK.	APP.	ECN

REVISIONS

DRN.	CHK.	APP.	SCALE
MLD	MAI	MAI	5" = 1"
DATE	DATE	DATE	.XX ± .015
03/01/07	03/19/07	03/19/07	.XXX ± .010



JOHANSON MANUFACTURING CORPORATION

ROCKAWAY VALLEY ROAD, BOONTON, N.J. 07005 (973)334-2676 FAX (973)334-2954
ELECTRONIC ACCURACY THROUGH MECHANICAL PRECISION