

CHIP RESISTOR, THIN FILM

FILE: CROUT

MATERIAL SPECIFICATIONS:

SUBSTRATE MATERIAL: CVD
 TERMINAL MATERIAL:
 THIN FILM, GOLD WIRE BONDABLE &
 SOLDERABLE WITH Sn96 SOLDER
 GND PLANE MATERIAL:
 THIN FILM, GOLD PLATED SOLDERABLE
 SURFACE, DESIGNED FOR ATTACHMENT
 WITH Sn96 SOLDER

RESISTIVE ELEMENT:
 MATERIAL - THIN FILM

RoHS COMPLIANT

DIMENSIONS IN BRACKETS IN [mm]

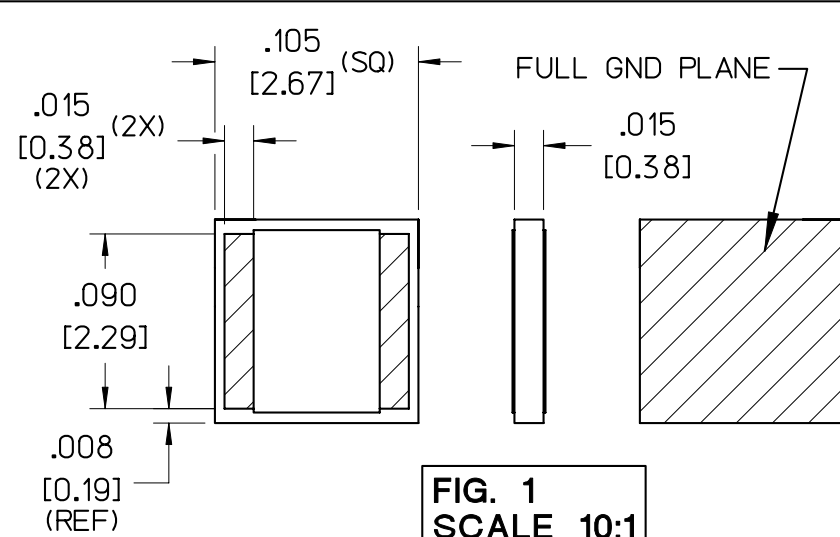

**FIG. 1
SCALE 10:1**

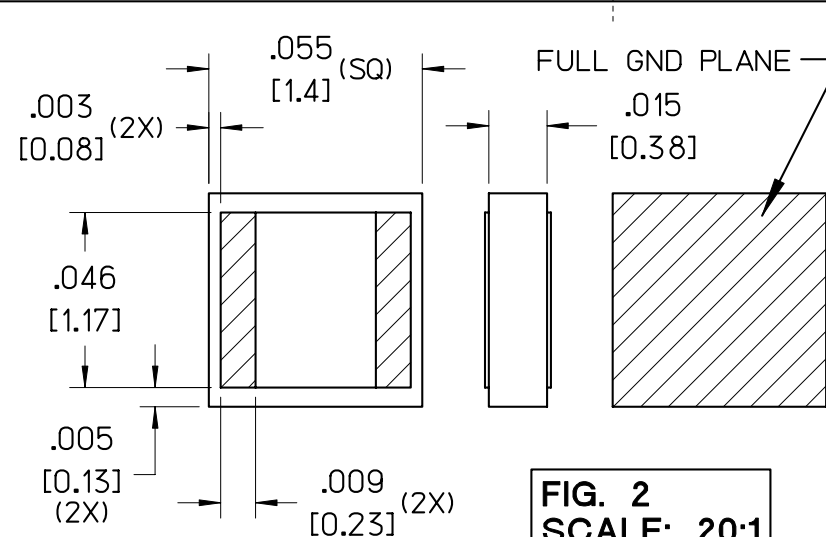

**FIG. 2
SCALE: 20:1**

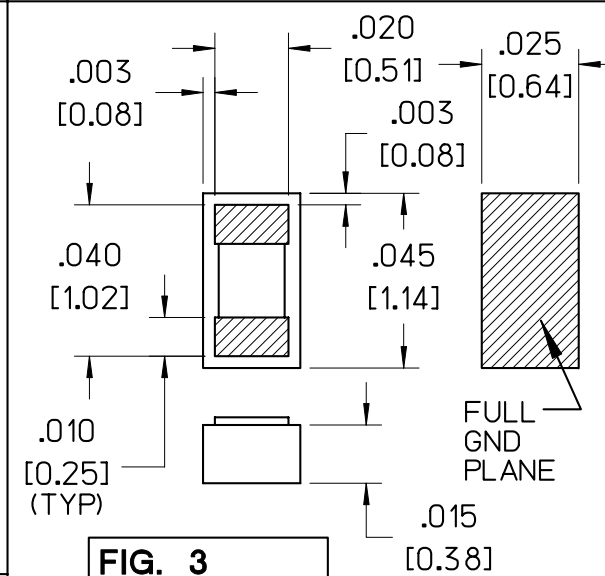

**FIG. 3
SCALE: 20:1**

SPECIFICATIONS FOR FIG. 1, 2 & 4

ELECTRICAL SPECIFICATIONS:

FIG. 1 INPUT POWER: 150 WATTS ON 100°C HEAT SINK.

FIG. 2 INPUT POWER: 50 WATTS ON 100°C HEAT SINK.

FIG. 4 INPUT POWER: 80 WATTS ON 100°C HEAT SINK.

MECHANICAL SPECIFICATIONS:

WORKMANSHIP: PER MIL-STD-454, REQUIREMENT 9.

ENVIRONMENTAL SPECIFICATIONS:

TEMPERATURE RANGE:
 OPERATING: -55°C TO +125°C.

UNIT MARKING: NONE.

SPECIFICATIONS FOR FIG. 3

ELECTRICAL SPECIFICATIONS:

INPUT POWER:
 20 WATTS ON 100°C HEAT SINK.
 DERATE POWER LINEARLY TO
 50% @ 125°C

MECHANICAL SPECIFICATIONS:

WORKMANSHIP:
 PER MIL-STD-454, REQUIREMENT 9.

ENVIRONMENTAL SPECIFICATIONS:

TEMPERATURE RANGE:
 OPERATING: -55°C TO +125°C.

UNIT MARKING: NONE.

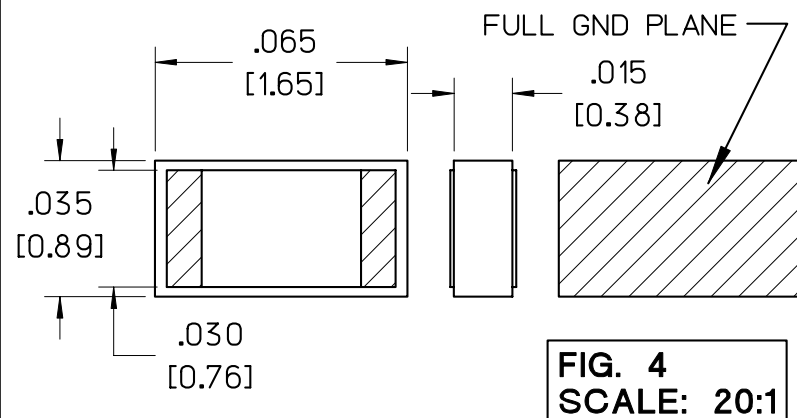

**FIG. 4
SCALE: 20:1**

PRODUCT SELECTION TABLE

JMC PART NO.	RESISTANCE RANGE (OHMS)	MAXIMUM FREQUENCY	CAPACITANCE (pF)	POWER RATING (WATTS)	POWER DERATING	FIGURE
CR0305F050G CR0305F100G	50±5% 100±5%	26.5	0.09	20	SEE GRAPH	3
CR0606F050G CR0606F100G	50±5% 100±5%	18.0	0.1	50	SEE GRAPH	2
CR0407F050G CR0407F100G	50±5% 100±5%	18.0	—	80	SEE GRAPH	4
CR1111F050G CR1111F100G	50±5% 100±5%	12.4	0.3	150	SEE GRAPH	1

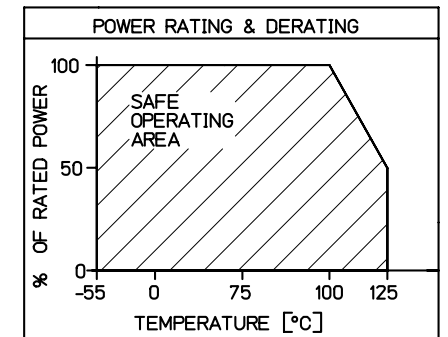

GRAPH FOR FIG. 3

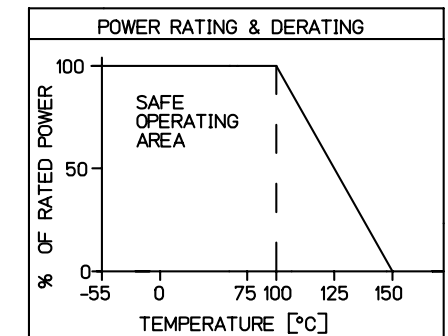

GRAPH FOR FIG. 1, 2 & 4

A	06/23/10	-	-	-	000843
LEVEL	DATE	DRN.	CHK.	APP.	ECN

REVISIONS

DRN.	CHK.	APP.	SCALE
BFH	MAI	MAI	20" = 1"
DATE	DATE	DATE	.XX±.02 [50] .XXX±.005 [127] ANG ±1/2°
06/23/10	07/01/10	07/01/10	



JOHANSON MANUFACTURING CORPORATION
 ROCKAWAY VALLEY ROAD, BOONTON, N.J. 07005 (973)334-2676 FAX (973)334-2954
 ELECTRONIC ACCURACY THROUGH MECHANICAL PRECISION

PROPRIETARY INFORMATION CONTAINED NOT TO BE USED WITHOUT JOHANSON MANUFACTURING CORPORATION APPROVAL