

PRELIMINARY

MI DRG NO. JCC-1006-1A REV. A

JCC-1006-1 A

TITLE
**OUTLINE, COUPLER, 90° ,
 470 - 860 MHz, 200W**

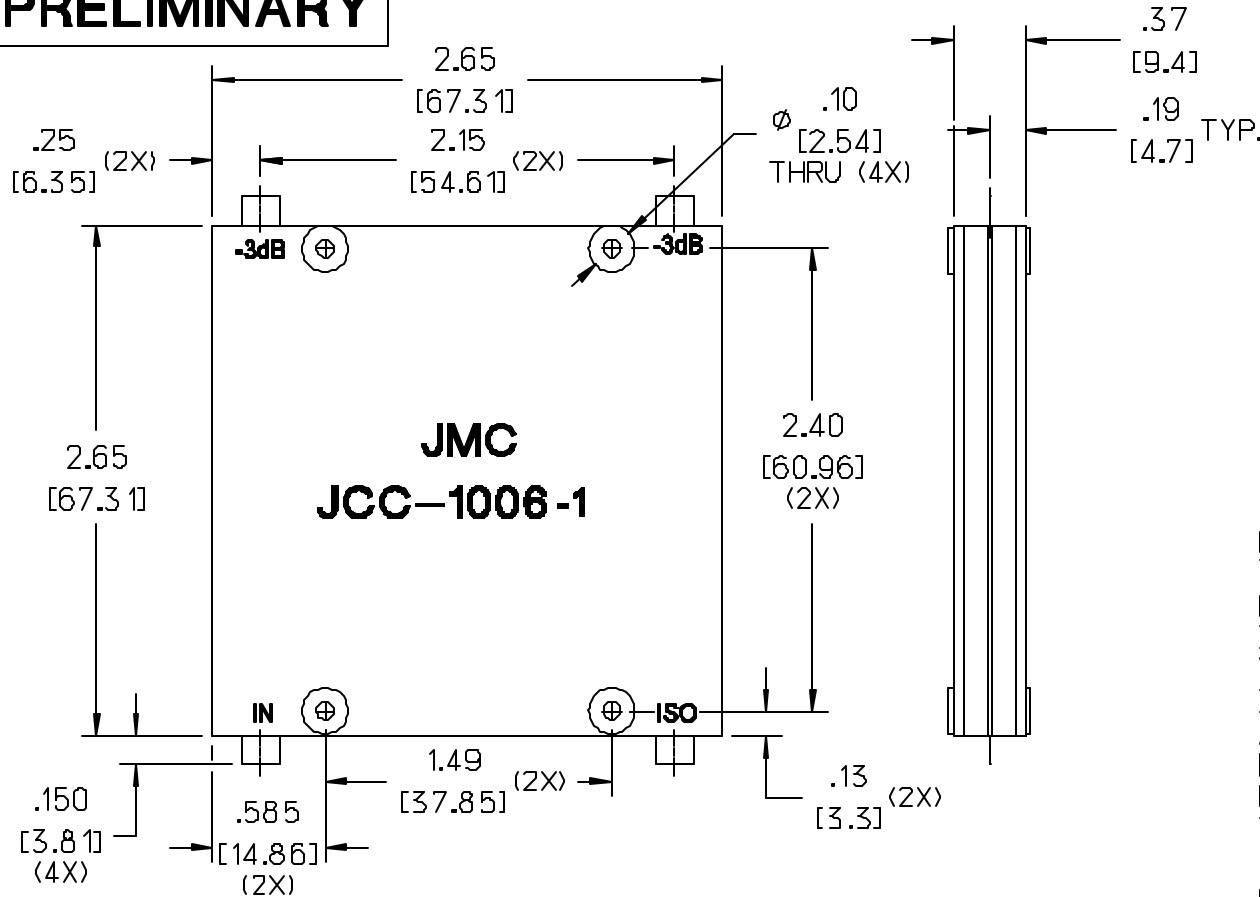

| SPECIFICATIONS | | FILE |
|----------------|--|------|
| MATERIAL | AL ALLOY, 6061-T6 | |
| FINISH | CHEM FILM, CLEAR PER MIL-C-5541, TYP 2 REV. F, CLASS 3 RoHS COMPLIANT | |

ELECTRICAL SPECIFICATIONS.

| | |
|-------------------|---------------|
| FREQUENCY: | 470 - 860 MHz |
| INSERTION LOSS: | <0.20 dB |
| VSWR: | <1.25: 1 |
| ISOLATION: | >18 dB |
| AMPLITUDE BALANCE | ±0.65 dB |
| PHASE BALANCE | ±5° |
| POWER: | 200 WATT |
| TEMPERATURE: | -55°C TO 85°C |

NOTES:

1. LEAD MATERIAL: 99.99% PURE SILVER .250 WIDE X .005" THICK
2. DIMENSIONS IN [mm]
3. RoHS COMPLIANT.

OPTIONAL SURFACE MOUNT PAD CONFIGURATION:

PART# JCC-1006-1SM

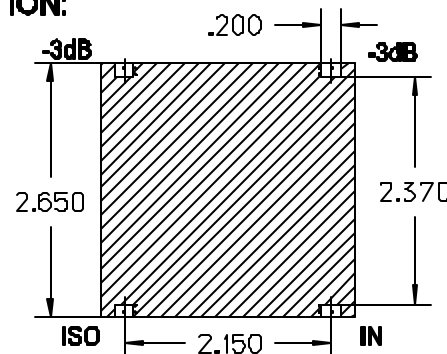

| LEVEL | DATE | DRN. | CHK. | APP. | ECN |
|-------|----------|------|------|------|------|
| A | 04/20/10 | SDJ | - | - | NONE |

REVISIONS

| DRN. | CHK. | APP. | SCALE: |
|----------|----------|----------|--|
| SDJ | SDJ | MAI | 1 1 |
| DATE | DATE | DATE | .XX±.02 [50] .XXX±.005 [127] ANG ±1/2° |
| 04/20/10 | 04/21/10 | 04/21/10 | |



JOHANSON MANUFACTURING CORPORATION
 ROCKAWAY VALLEY ROAD, BOONTON, N.J. 07005 (973)534-2676 FAX (973)534-2954
 ELECTRONIC ACCURACY THROUGH MECHANICAL PRECISION

PROPRIETARY INFORMATION CONTAINED NOT TO BE USED WITHOUT JOHANSON MANUFACTURING CORPORATION APPROVAL